

Series SG73-B	
Size Range	50mm~1600mm (2"~64")
Body Style	Wafer
Temperature Range	-46°C~850°C
Pressure Range	0.6MPa~2.5 MPa(Class150)
Body Materials	WCB, LC1, CF8, CF8M, 321, 316Ti, 904L, 310S, 2507
Disc Materials	304, 316, 321, 316Ti, 904L, 310S, Duplex
Stem Materials	420, 431, 304, 316, 316L, 321
Seat Materials	EPDM, NBR, NR, PTFE, Viton, 420, STL, Ceramics
Installation Direction	Unidirectional, Bidirectional
Face to Face	GB/T15188
Design	JB/T8691
Flange Drilling	ASME B16.5, EN1092, GOST33259, DIN2501
Top connection	ISO5211, GOST55510
Inspection	GB/T13927, ISO5028, API598, JB/T9092

**SG73-B**  
Wafer Knife Gate Valve Type B

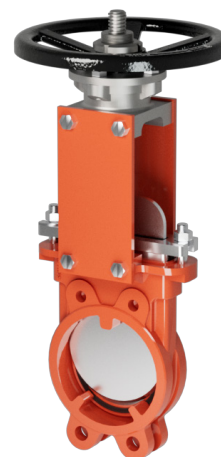

S	G(Type)	×(Driving)	7(Connection)	3(Structure)	S(Sealing material)	-	10(Pressure)	C(Body material)
Seallon	G-gate valve	×-handwheel 0-yoke 5-gear box 6-pneumatic 9-electric	7-wafer	3-knife gate	R-rubber P-plastic S-stainless steel	-	10 16 25	C-cast steel S-stainless steel

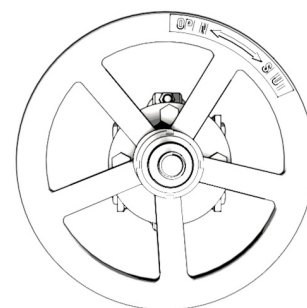
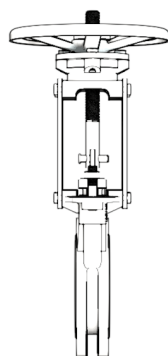
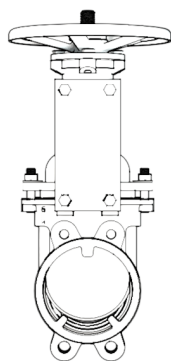

DN	50	65	80	100	125	150	200	250	300	350	400	450	500	600	700	800	900	1000	1200	1400	1600	
L (F-F, mm)	48	48	51	51	57	57	70	70	76	76	89	89	114	114	127	127	127	149	156	171	198	
Torque (1.0Mpa)	39	55	65	70	77	116	130	133	150	154	215	231	327	347	462	693	892	923	1385			
Bare stem weight (kg)	9	10	13	15	20	24.5	35	52	62	86	111	159	217	312	477	735	880	1100	1980	3800	4000	