

| Series SD41            |   |
|------------------------|---|
| Size Range             | 15mm~600mm (1/2"~24")                           |
| Body Style             | Flanged   |
| Temperature Range      | -46°C~180°C                                     |
| Pressure Range         | 0.6Mpa~1.6Mpa (Class150)                        |
| Body Materials         | GGG40, WCB, CF8, CF8M                           |
| Diaphragm Materials    | 11R, NR, NBR, EPDM, CR, FPM, FEP, PFA           |
| Stem Materials         | 420, F6a, F304, F316                            |
| Seat Materials         | GGG40, WCB, CF8, CF8M                           |
| Installation Direction | Bidirectional                                   |
| Face to Face           | GB/T12221, BS5156, ISO5752, EN558, DIN3202      |
| Design                 | GB/T12239, BS5156                               |
| Flange Drilling        | ASME B16.5, EN1092, GOST33259, DIN2501, ISO2084 |
| Top connection         | ISO5211, GOST55510                              |
| Inspection             | GB/T13927, ISO5028, API598, JB/T9092, BS5156    |

**SD41**  
Flanged Diaphragm Valve

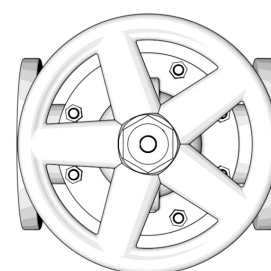

| S       | D(Type)           | ×(Driving)   | 4(Connection) | 1(Structure) | R(Sealing material)   | - | 10(Pressure)  | C(Body material)                                    |
|---------|-------------------|--|---------------|--------------|-----------------------|---|---------------|---|
| Seallon | D-diaphragm valve | ×-handwheel<br>0-yoke<br>5-gear box<br>6-pneumatic<br>9-electric | 4-flanged     | 1-common     | R-rubber<br>P-plastic | - | 6<br>10<br>16 | D-ductile iron<br>C-cast steel<br>S-stainless steel |

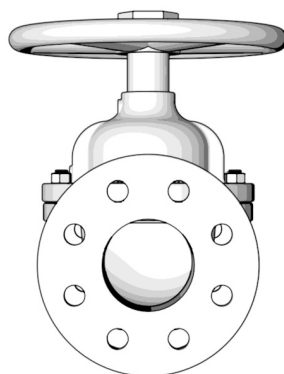
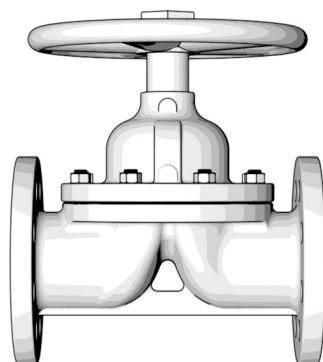

|             |     |     |     |      |     |     |     |     |     |     |
|-------------|-----|-----|-----|------|-----|-----|-----|-----|-----|-----|
| DN          | 25  | 32  | 40  | 50   | 65  | 80  | 100 | 125 | 150 | 200 |
| L           | 127 | 146 | 159 | 190  | 216 | 254 | 305 | 356 | 406 | 521 |
| Weight (KG) | 5   | 7   | 9.5 | 11.5 | 16  | 22  | 28  | 50  | 65  | 115 |